

How To Design Stac-King Portable Racks

1. Select Rack Capacity.

Standard Duty (SD) = 2,000# each
Heavy Duty (HD) = 4,000# each

2. Determine Rack Size.

Remember to allow room for the corner sockets. Because the rack size refers to the overall dimensions of the base, **it is important to remember that the corner columns and base sockets are within the overall base dimensions.**

Add at least 3 1/2" to either width or length of your load for Standard Duty racks

Add at least 5" to either the width or length of your load for Heavy Duty racks

Example: If your load is 42" x 48" and weighs 4000#

42" + 5" = 47". You would need at minimum a 47" x 48" Heavy Duty Rack

Note: Your load may overhang the rack base in one direction

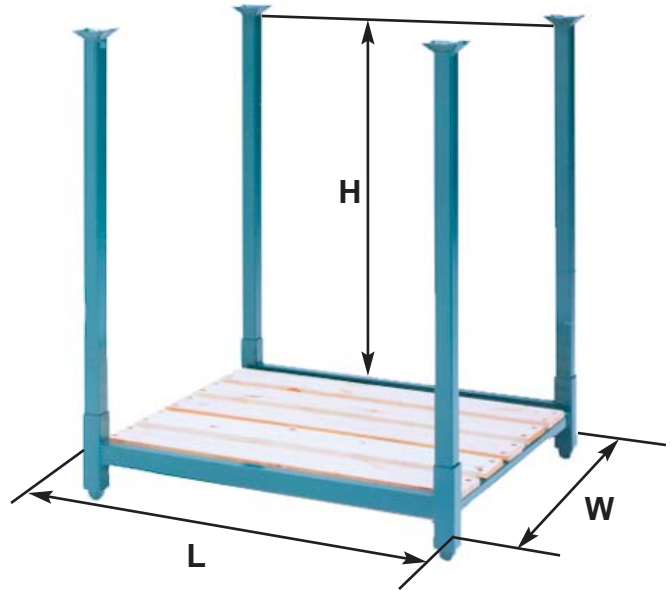

What can happen if you don't take into account the size of the columns?

Lets say you planned on placing 6 packages on a Stac-King portable rack, each with a size of 7 1/2" x 7 1/2" x 46" long. The width of all six packages totals 45", so you order a 46" wide portable rack base.

Because you did not take the corner column dimensions into consideration, you will only be able to load 5 of your packages on to the portable rack base.

This is a storage loss of nearly 17%.

In order to meet your preferred load pattern, at least one base dimension needed to be increased to a 49" minimum (45" + 3 1/2" = 48 1/2" or 49").

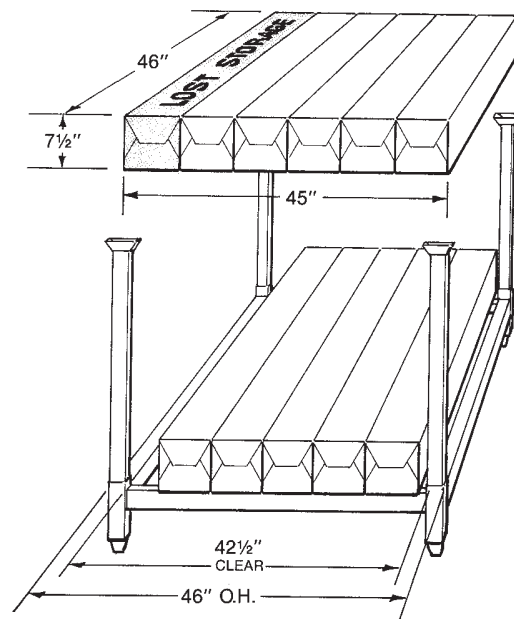

3. Determine Base Design: Long Fork versus Short Fork Design

When ordering a portable rack, you will be asked whether you need a short fork or a long fork base design. The right choice for your application is a function of the base size of the rack and the length of the forks on your lift truck. The key is that the forks of the lift truck must not be able to contact the decking material or the load.

Long Fork Base Designs are used when the length of the forks on the lift truck are longer than the shortest rack base dimension. In this situation, the forks will be in contact with both outer frames of the rack base.

Short Fork Base Designs should be specified when the lift truck forks are shorter than the shortest base dimension.

Use the diagrams below, to help clarify which fork base design would be most appropriate for your application.

Long Fork Base

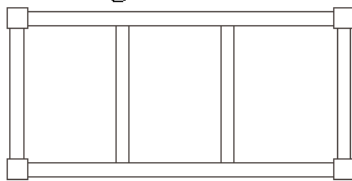

Short Fork Base

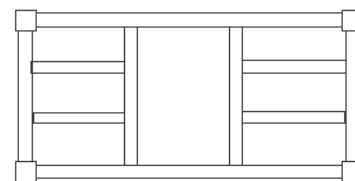

Lift truck forks are longer than shortest base dimension.

Long Fork Base design would be appropriate.

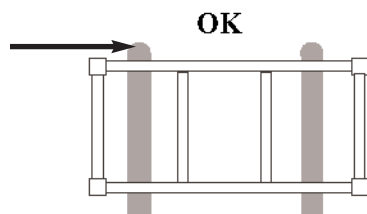

Lift truck forks are shorter than shortest base dimension.

Would need to purchase Short Fork Base design.

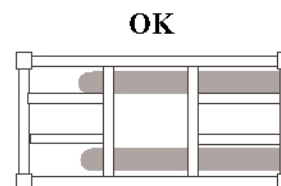
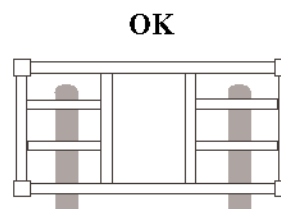
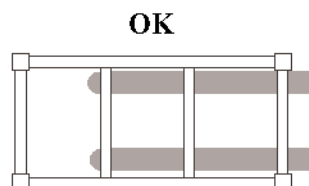
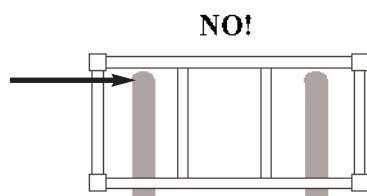

4. Select Base Decking

Stac-King racks can be purchased with a variety of base decking options. Deck options include open, plywood, wood boards, sheet metal or expanded metal mesh.

Below are examples of the various base choices:



Open Deck



Wood Board Deck



Plywood Deck



Expanded Metal Deck



Sheet Metal Deck

Wood Board Decks - A wood board deck is made up of 1" x 6" non-finished boards running the length of the longest dimension of the base. The boards are spaced 1" - 2" apart and are held in place by 4 counter sunk hex head screws with washers.

Plywood Decks - Plywood decking is available in 1/2" or 3/4" thicknesses. Plywood decks can have corners notched to fit flush on all 4 sides of the base. Plywood decks are generally tec screwed into position.

Expanded Metal Deck - Ends of expanded metal decks are always captured in a 1" channel so that there are no sharp edges exposed. Expanded metal decks are generally welded to the rack base.

Sheet Metal Deck - Sheet metal decking is available in any gauge depending on load requirements. The standard sheet metal deck is made of 14 gauge material. Ends of sheet metal decks are always waterfalled over the base supports, providing smooth flat edges. Sheet metal decks are generally welded to the rack base.

Other Decks available - Special decks such as Masonite, pressed board or wire mesh are available, consult with Steel King to meet your requirements.

5. Select Column Height

Column height is clear height above deck and does not include the stacking targets. Generally, columns can be of any reasonable height above the deck, however when a height in excess of 42" is specified, the base socket will need to be proportionately higher to compensate for the leverage forces that come into play during the stacking procedure.

Standard Duty Columns (SDC) - 2,000# capacity rating
Heavy Duty Columns (HDC) - 4,000# capacity rating

6. Determine Base Socket Size

A high base socket may be desirable for your application. All portable racks with columns 42" or more in height above the deck require high sockets for increased stability.

Standard Base Sockets - 6" High
High Base Sockets - 9" High

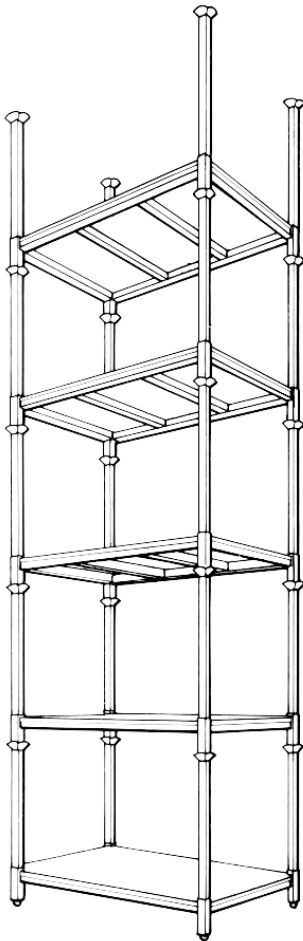
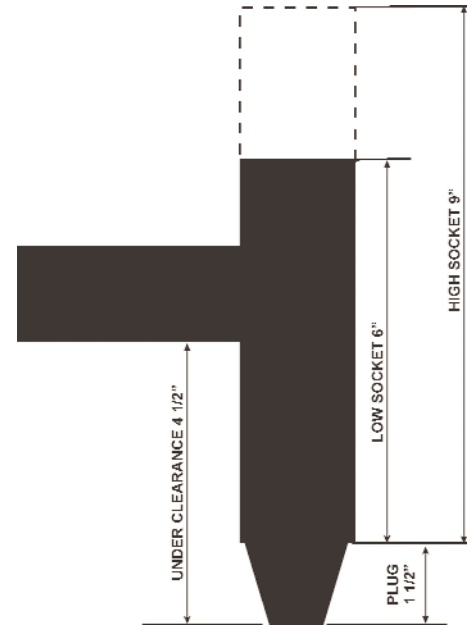

How many portable racks can I stack?

Standard Steel King portable racks can be stacked 6 high, while fully loaded to their design capacity.

The number of portable racks that can be stacked (nested) is based on:

- 1) Load weight;
- 2) Column height & material (gauge of steel); and
- 3) Base size.

Loading Patterns

Another important factor to consider when determining if you need a high base socket or special posts is whether the type of load and loading pattern planned for the portable rack is standard.

Loads, by the nature of how they sit on a portable rack, can apply pressure against the corner columns requiring the use of a high base socket or special posts. In an extreme situation, loads which apply too much pressure to the columns may require the portable rack to be designed with top ties or other options.

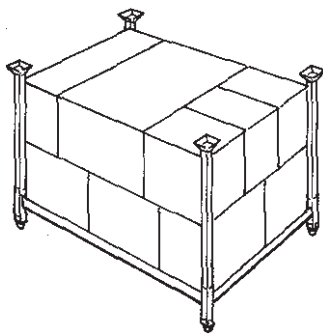

**Self Contained
Uniformly Loaded Base**
"OK"

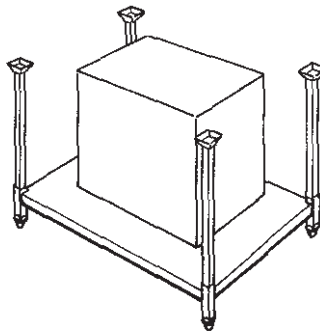

**Self Contained
Concentrated Point Load Base**
"May Require Special Design"

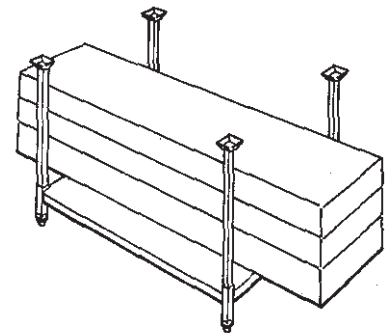

**Long, evenly distributed load
with overhanging ends.**
"OK"

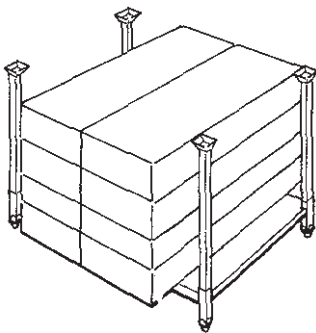

**Evenly distributed load with
overhanging ends, applies very
little pressure to corner columns.**
"OK"

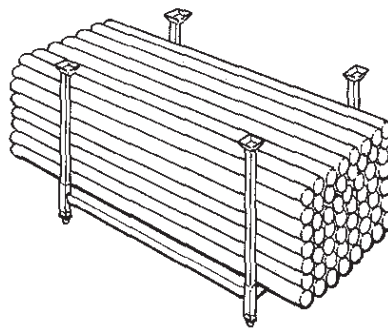

**Load is not self contained and
overhangs end, creating pres-
sure against corner columns.**
"May Require Special Design"

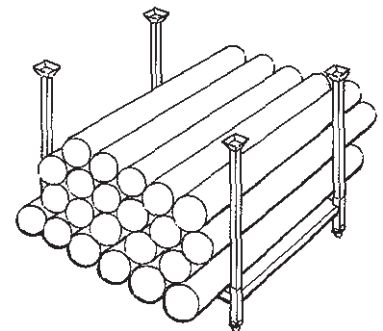

**Loose load is not self contained,
and applies considerable pres-
sure to corner columns.**
"May Require Special Design"

7. Add Special Features

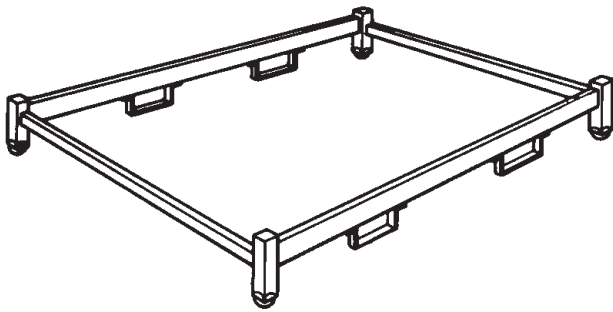

Fork Stirrups:

Fork stirrups can be added to Stac-King portable racks for help in centering a load. Also, fork stirrups will virtually guarantee that the fork truck operator picks up the rack correctly each time. Generally used in those situations where the length of the rack is considerably longer than usual or where uneven loads are difficult to handle.

Skid Bars:

Skid bars will help disperse bearing weight for ease of moving units on the floor. Also could be used in those rare applications when you need to place your portable rack in a pallet rack installation or placed on a roller conveyor.

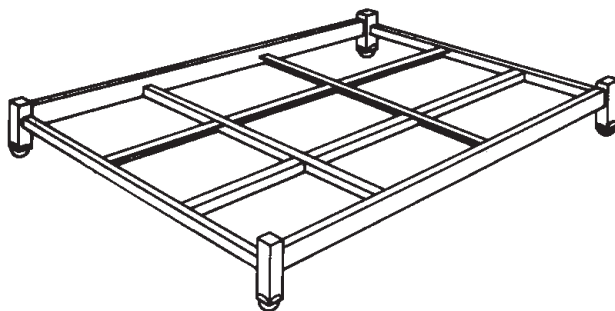
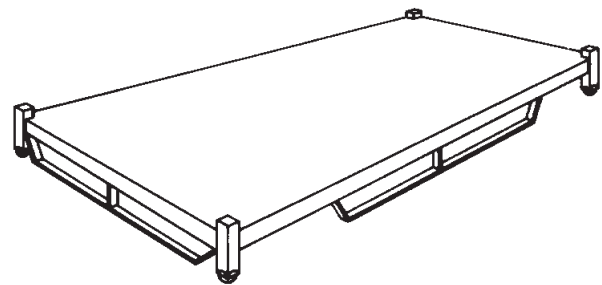

Filled In Bases:

Filled in bases are advisable on occasion, depending on the concentration of your load.

7. Select Paint Color

Steel King stocks twelve standard paint colors. Use this feature to identify racks of various load carrying capacities or to differentiate storage locations. We offer the following colors: Industrial Yellow, Poppy Orange, Apricot Orange, Cubic Blue, Precaution Blue, Navy Blue, Fire-Engine Red, Vista Green, Kelly Green, Cubic Gray, Mist White, and Platinum Tan. Galvanizing is also available at extra cost.