



## Effect of Column Shape Upon Frontal Damage Resistance

### Test #032594-A

Additional testing has been performed recently on SK2000 racking, for the purpose of quantifying several of the design advantages inherent in the SK2000 design. The results of these tests are outlined below.

Steel King's SK2000 series pallet rack frame columns are constructed of closed tubular steel sections. Other rack manufacturers offer open-back, roll-formed columns (See Figure 1). A test was performed to quantify the difference in the ability of these designs to resist a direct frontal impact.



The SK2000 frame type, and the industry standard frame type, were tested as shown in Figure 2. All columns tested were of an equivalent steel thickness and column size. The test load was evenly distributed across the face of the column, but was concentrated midway between horizontal braces (this imitates the manner in which many accidental fork lift truck impacts occur). The testing machine applied a continually increasing load weight, and the point at which each assembly yielded (failed) was recorded. The identical procedure was employed in testing both rack frame types.

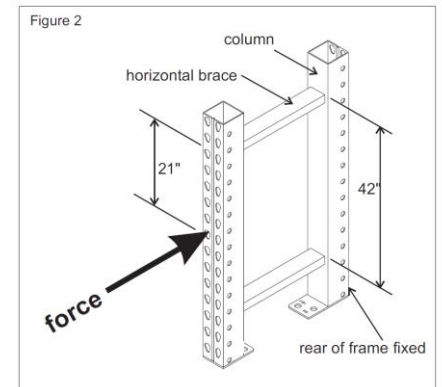

The industry standard, open-back (roll-formed) frame assembly failed at 3,200# of pressure. When subjected to a similar 3,200# load, the SK2000 assembly exhibited no deflection, nor any visually detectable damage. The SK2000 frame assembly continued to withstand increasingly heavy amounts of pressure, until reaching its own yield point of 4,700# (See Figure 3).

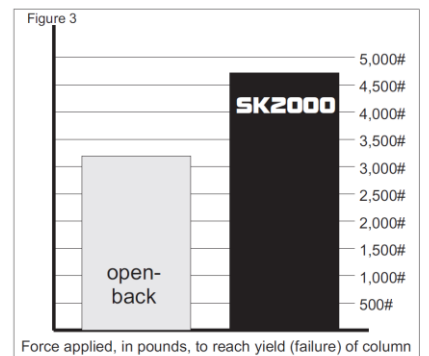

**CONCLUSION: Users of SK2000 rack systems can expect decreased maintenance costs, and improved safety, by taking advantage of the 47% greater strength proven by this test. This is only one feature of the SK2000 system that gives users more value for their investment.**

**Steel King is Built to Deliver ...**



## Effect of Column Shape Upon Side-Damage Resistance

### Test #032594-B

Additional testing has been performed recently on SK2000 racking, for the purpose of quantifying several of the design advantages inherent in the SK2000 design. The results of these tests are outlined below.

Steel King's SK2000 series pallet rack frame columns are constructed of closed tubular steel sections. Other rack manufacturers offer open-back, roll-formed sections (See Figure 1). A test was performed to quantify the difference in the ability of these two designs to withstand side impacts.



The SK2000 column type, and the industry standard column type, were tested as shown in Figure 2. All columns tested were of an equivalent steel thickness and column size. The test load was evenly distributed across the side of the column, but was concentrated midway along its height (this imitates the manner in which many accidental fork lift truck impacts occur, especially in drive-in configurations, or at ends of rack rows). The testing machine applied a continually increasing load weight, and the point at which each column yielded (failed) was recorded. The identical procedure was employed in testing both column types.

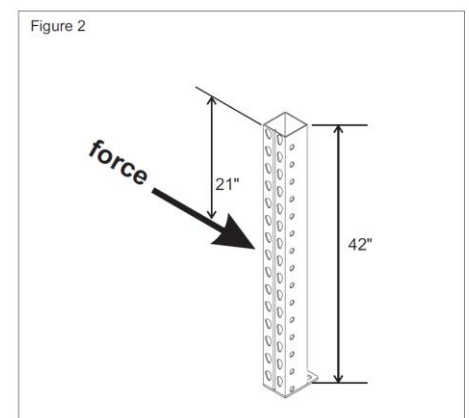

The industry standard, open-back (roll-formed) column failed at 1,900# of pressure. When subjected to a similar 1,900# load, the SK2000 closed tubular column exhibited no visually detectable damage. The SK2000 column continued to withstand increasingly heavy amounts of pressure, until reaching its own yield point of 3,200# (See Figure 3).

**CONCLUSION:** Users of SK2000 rack systems can expect decreased maintenance costs, and improved safety, by taking advantage of the 68% greater strength proven by this test. This is only one feature of the SK2000 system that gives users more value for their investment.

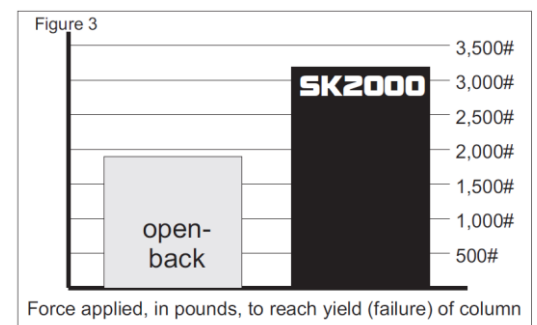

**Steel King is Built to Deliver ...**