

I-Beam Cantilever Installation and Assembly Manual

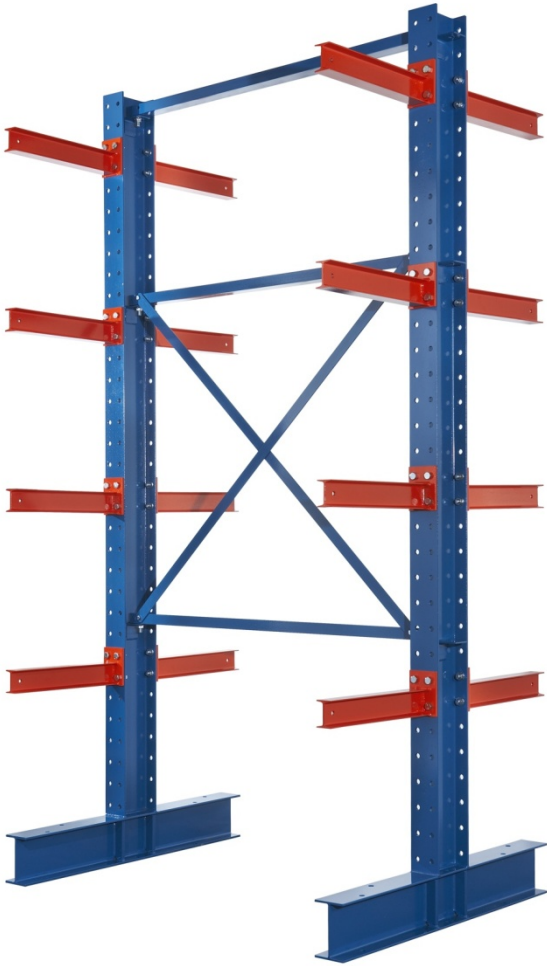

Steel King Industries, Inc.

2700 Chamber St

Stevens Pont, WI 54481

(800) 826-0203

www.steelking.com

info@steelking.com

ASSEMBLY INSTRUCTIONS:

Steel King Industries recommends that this product be assembled only by qualified personnel, experienced in assembly of storage racks, and knowledgeable of all safety regulations and practices. These instructions are intended only for use by qualified individuals using all proper safety equipment.



These storage racks are extremely heavy, and if not properly secured during installation and assembly could fall, possible causing injury or death as well as damage to property.

Contact Steel King Industries or your local Steel King Representative for the name and contact information of a qualified installer. Users of this information agree to indemnify and hold harmless Steel King Industries from any and all liability.

Step #1: Check the Material

- A. Check to make certain that all materials have been received. Materials should be checked against the packing lists and Bill of Lading.
- B. Notify the shipper immediately of any shortages or product damage.

Step #2: Check the Area:

- A. Clear the area where the rack system is to be located.
- B. Check the area for all obstruction, such as lights, heating ducts, pipes, building columns, etc., to insure a clear area for the installation of the storage rack.

Step #3: Lay Out floor:**Recommended tools:**

- Tape Measure
- Chalk Line

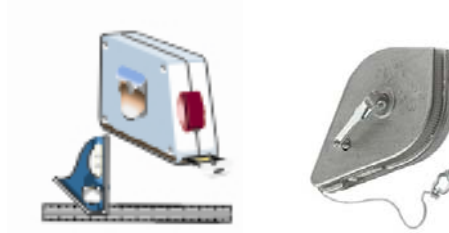

- A. Establish the rack lay out by determining the aisle dimensions and the rack position.

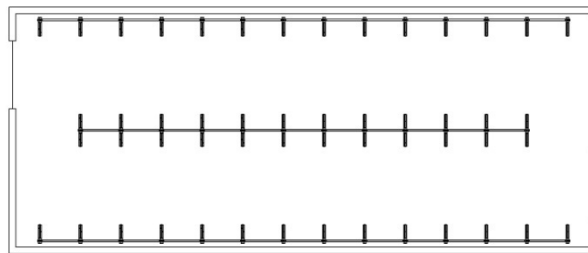

- B. Snap a chalk line establishing the front edge of the upright bases. The chalk line should run the entire length of the row of rack.

Step #4: Assemble I-Beam Cantilever Rack:**Recommended tools:**

- Air compressor,
- Torque wrench,
- 1 1/8" drive impacts or equivalent



- A. Distribute the uprights, bases, arms and bracing for assembly near their final installed position. Use dunnage to protect the floor during this operation.

- B. Mark the arm elevations on the uprights. The marks should be below the top of the arm end plate so as not to show after the arm is bolted in place.

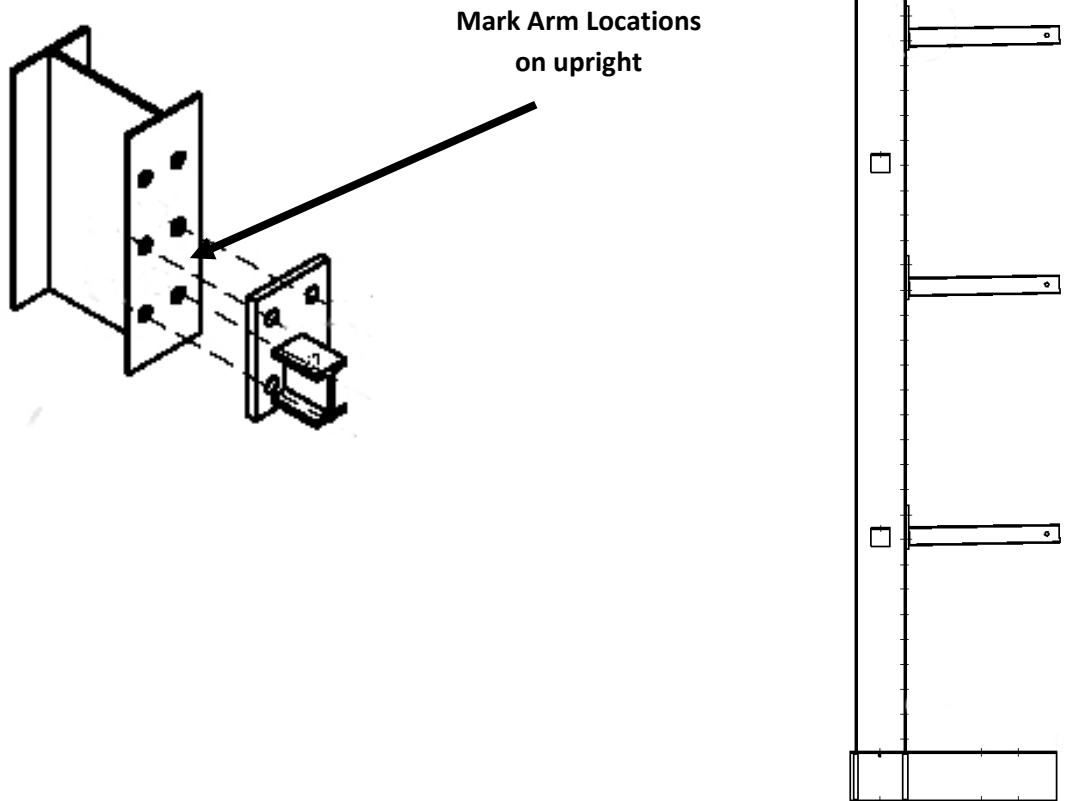

Step #4: Assemble I-Beam Cantilever Rack Continued:

- C. Bolt the arms and the bases to the uprights using the $\frac{3}{4}$ " diameter x 2" long bolts. Torque the bolt to 200 ft-lbs.

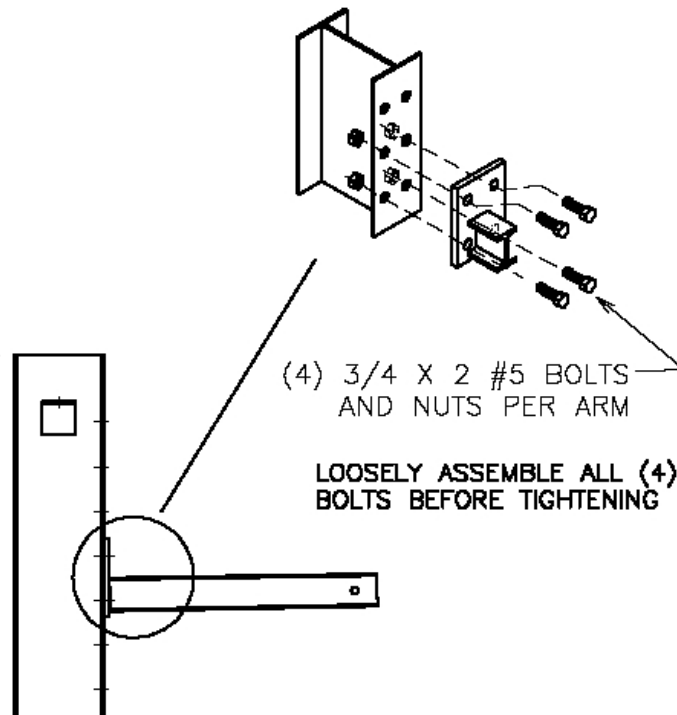
**Step #5: Erect Upright Columns:****Recommended tools:**

- Fork truck or other mechanical lifting device,
- Air compressor,
- Torque wrench,
- 1 1/8" drive impacts or equivalent



- A. Using a fork truck, carefully stand the pre-assembled uprights with arms attached. Please be careful here to protect the floor.

- B. For each row, assemble a starter bay. A starter bay includes two preassembled uprights with attached arms and all support bracing, both diagonal and horizontal. See Starter Bay Configuration Figure Below.

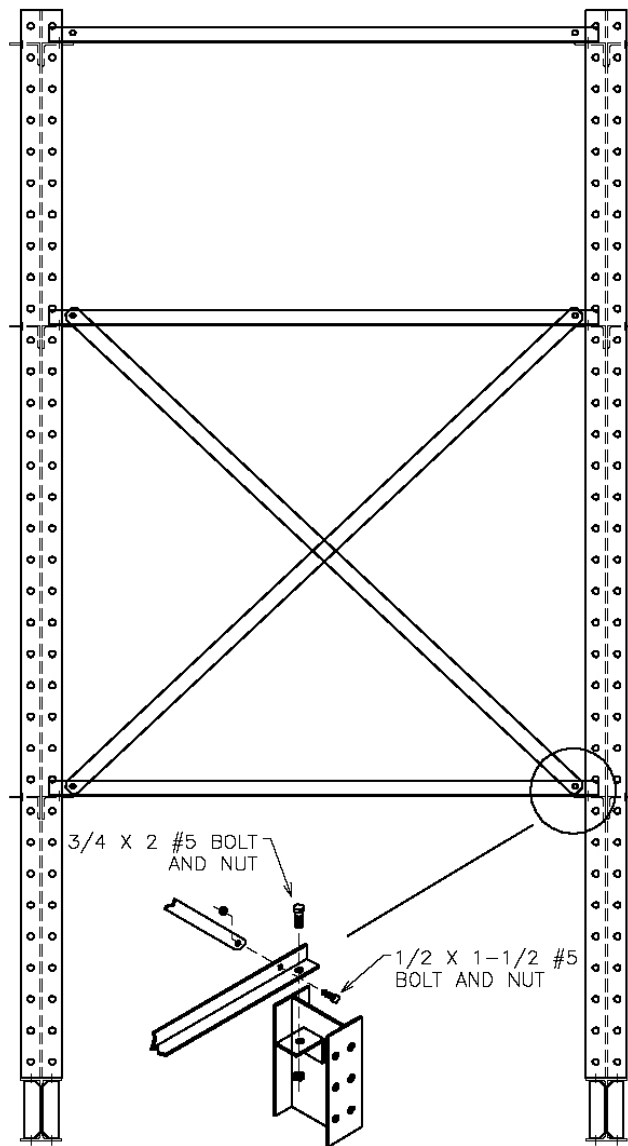

LOOSELY ASSEMBLE ALL BRACING COMPONENTS BEFORE TIGHTENING

Step #5: Erect Upright Columns Continued

- C. Tighten all bracing.

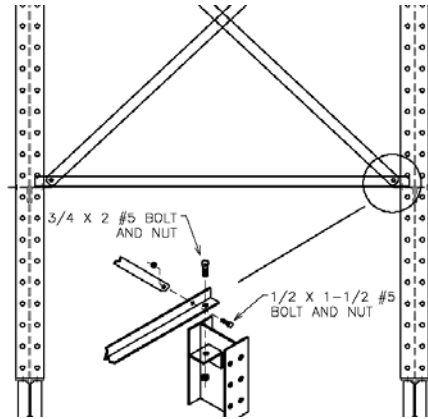

- D. A spacer should be used to assure proper spacing between the bases.
- E. Now the balance of the uprights can be erected to complete the run. The uprights can be stood either one at a time or in groups of 2.
- If 2 uprights are to be erected, this should be the bay with the X-bracing tightened in place.

Step #6: Square, Plumb, Shims, and Anchor Bolts:

- A. Square the bases of the uprights on the chalk lines.
- B. Plumb the uprights vertically. Use shims to adjust.
- C. Shim the upright and base assemblies such that the columns maintain an out-of-plumb tolerance of $\frac{1}{2}$ " or less in 10 feet. Bases must be fully secured to the columns before shimming. Shims are to be positioned at an anchor bolt.

Note: Proper shimming is important because it affects the alignment of the arms.

- D. For non-seismic applications, anchor the upright and base assemblies to the slab-on-grade per the following configurations using $\frac{3}{4}$ " diameter x $5\frac{1}{2}$ " long anchor bolts. The recommended installation torque for these anchor bolts is 150 foot-pounds. Anchor holes are to be vacuumed out before inserting the anchor bolts.

Proper Anchor Configurations For Single and Double Sided I-Beam Cantilever Racks

Single Sided, I-Beam Cantilever Anchor Configuration – Top View

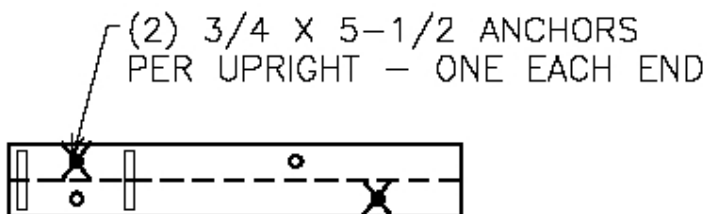

Double Sided I-Beam Cantilever Anchor Configuration – Top View

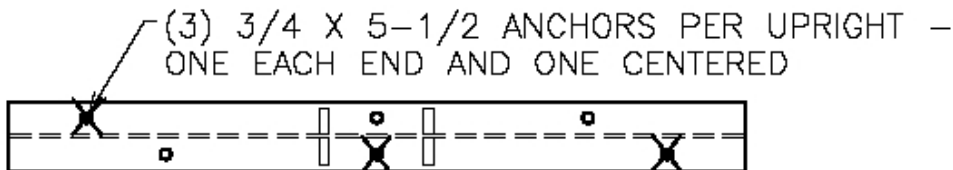

Step #7: Clean-up:

- A. Vacuum all dust and debris associated with setting anchors.
- B. Dispose of all dunnage, strapping and debris. Sweep the floor with a broom if necessary.



If you have any further questions, contact your local Steel King Representative for customer assistance or contact Steel King Industries directly at (800) 826-0203.

WARNING: INSTRUCTIONS FOR ASSEMBLY ARE SET FORTH ON THESE PAGES. PROPER ASSEMBLY IS THE RESPONSIBILITY OF THE PURCHASER AND IS NOT COVERED BY ANY WARRANTY OF THE SELLER. BUYER IS CAUTIONED NOT TO SUBSTITUTE PARTS OR HARDWARE. SELLER DISCLAIMS ALL LIABILITY WITH RESPECT TO ANY SUBSTITUTION OF PARTS OR HARDWARE NOT APPROVED IN WRITING BY SELLER.

THE INSTALLATION DETAIL DRAWINGS THAT FOLLOW ARE INTENDED AS BASIC GUIDES FOR INSTALLATION OF THE STANDARD COMPONENTS. DEPENDING UPON THE SPECIFICS OF THE SYSTEM, THERE MAY BE LIMITATIONS REGARDING THE USE OF THESE STANDARD COMPONENTS AND/OR A REQUIREMENT FOR SPECIAL INSTALLATION TECHNIQUES. ADDITIONAL INFORMATION IS FOUND IN STEEL KING PRICE BOOKS, PUBLISHED TECHNICAL DOCUMENTS, COMPREHENSIVE INSTALLATION DRAWINGS, AND OTHER MATERIALS.