

SK2500 Boltless Tubular Pallet Rack Model Number System

Upright Frames

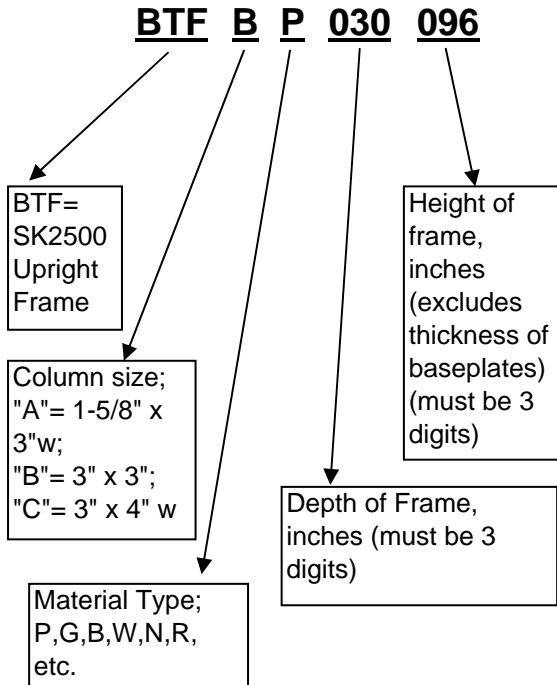

Step Beams

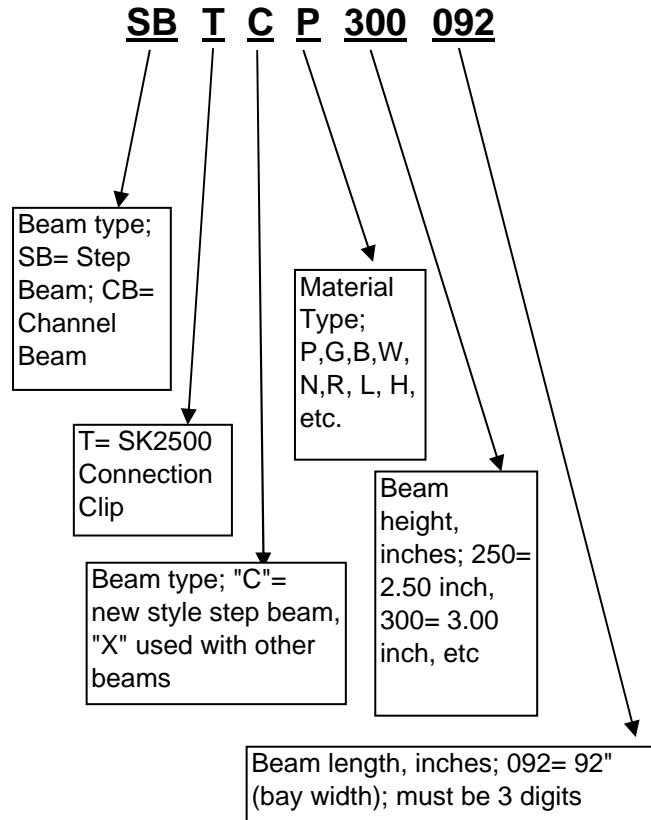

STEEL KING POWDER COAT PAINT ADVANTAGE

SK2500 Boltless Tubular Pallet Rack is painted with a high-durability POWDER COAT paint finish. Powder coated products offer better resistance to water and corrosion, better gloss, hardness, and adhesion. In fact, Steel King powder coated products give you:

- 60% GREATER RESISTANCE TO SOLVENTS
- 74% GREATER RESISTANCE TO SALT SPRAY
- 94% GREATER IMPACT RESISTANCE

As a Steel King dealer, this means that your customer's equipment looks better, arrives in better shape with fewer freight claims, requires less maintenance, and lasts longer. Selling Steel King powder coated products is better for the environment too, because unlike liquid paints, powder coat paints do not emit fumes into the air and generates less waste.



Steel King Industries Inc.

SK2500 Tubular BOLTED Pallet Rack Upright Frame Capacity Chart

6/1/2004



Upright Frame Post Type:	BTFAP	BTFAG	BTFBP	BTFBG	BTFBB	BTFBW
Nom. Post Size:	3" x 1-5/8"	3" x 1-5/8"	3" x 3"	3" x 3"	3" x 3"	3" x 3"
MAX vertical Beam Spacing:						
36"	19,000#	25,100#	25,100#	36,900#	45,000#	51,400#
42"	18,400#	24,200#	23,570#	34,200#	41,600#	47,500#
48"	16,730#	21,860#	21,900#	31,420#	38,000#	43,340#
54"	15,000#	19,440#	20,120#	28,490#	34,280#	39,050#
60"	13,270#	17,050#	18,280#	25,530#	30,540#	34,760#
66"	11,570#	14,740#	16,400#	22,600#	26,890#	30,560#
72"	9,920#	12,540#	15,540#	19,770#	23,390#	26,540#
78"	8,520#	10,700#	12,710#	17,050#	20,060#	22,730#
84"	7,390#	9,250#	11,100#	14,740#	17,290#	19,600#
90"	6,470#	8,060#	9,770#	12,870#	15,060#	17,070#
96"	5,710#	7,100#	8,660#	11,330#	13,240#	15,000#
over 96"	<i>Consult Factory</i>					

IMPORTANT NOTES TO CHART:

The above listed component capacities are based upon RMI 1997 Design specifications. System compliance includes consideration of connections. The great array of potential beam and column combinations cannot be represented in a chart format. For verification of *system* compliance to RMI 1997, or conformance to other local or regional codes, please consult our corporate office.

NOTE: On SK2500 rack, step beams are bolted above the beam.

Make sure to order uprights minimally 2" higher than the top beam level!

- 1) MAXIMUM LOAD PER SHELF LEVEL ON "BTFAP" & "BTFBP" = 7500#.
- 2) Capacities based upon interior usage.
- 3) Capacities are for selective rack only.
- 4) The above capacities do not consider seismic loading.
- 5) Each column/post of each frame MUST be anchored to an adequate concrete floor.
- 6) Capacities based upon installation in a plumb condition.
- 7) Capacities are total per upright, assuming equal loading on both posts.

If any of these conditions do not apply to your application, or if you are unsure if they apply, DO NOT USE THIS CHART; in those cases, consult Steel King Engineering dept. for design information.

- 8) Safety Factor = 1.8:1 per AISI 1996
- 9) Capacities are to be reduced to account for the weight of the rack system; deduct the weight of beams, frames, decking, and accessories.
- 10) Other frame capacities are available for applications with large quantities; consult the factory.
- 11) RMI 1997 recommends the use of optional accessories to reduce damage to frames. Items including column protectors, double columns, and guard rail are available from Steel King.

HOW TO USE THIS CHART:

- 1) Calculate the maximum load per bay; number of levels X load per level (supported levels only).
- 2) Determine the MAXIMUM distance between levels, or the distance from the floor to the first beam level, whichever is greater. This dimension is the "vertical beam spacing" to use in the above chart.
- 3) Using the "vertical beam spacing" as determined in step 2 above, follow the appropriate row towards the right until you find a capacity equal to or greater than the capacity required, as determined in step 1.
- 4) You may wish to choose an even greater capacity upright, for additional abuse resistance.
- 5) Verify the adequacy of the end user's floor to support these loads.

Steel King Beam Capacity Chart; Step Beams, SK2500 Bolted Rack Only.



Beam Series:	SBTCP250	SBTCP300	SBTCP350	SBTCP400	SBTCP425	SBTCP450	SBTCP500
Beam Height:	2.50"	3.00"	3.50"	4.00"	4.25"	4.50"	5.00"
Beam Length	Capacity	Capacity	Capacity	Capacity	Capacity	Capacity	Capacity
48"	5,180#	6,900#	8,460#	10,550#	11,610#	12,720#	15,000#
54"	4,640#	6,180#	7,740#	9,440#	10,380#	11,380#	13,500#
60"	3,940#	5,610#	7,020#	8,560#	9,400#	10,300#	12,230#
66"	3,280#	5,150#	6,430#	7,820#	8,600#	9,430#	11,190#
72"	2,780#	4,410#	5,930#	7,220#	7,940#	8,700#	10,320#
78"	2,590#	3,700#	5,400#	6,700#	7,380#	8,070#	9,590#
84"	2,360#	3,575#	4,850#	6,270#	6,890#	7,550#	8,960#
90"	2,190#	3,325#	4,495#	5,775#	6,470#	7,080#	8,420#
92"	2,140#	3,268#	4,400#	5,580#	6,247#	6,947#	8,257#
96"	2,040#	3,155#	4,210#	5,190#	5,800#	6,680#	7,930#
102"	1,760#	2,765#	3,570#	4,700#	5,170#	5,960#	7,510#
108"	1,470#	2,335#	3,065#	4,205#	4,640#	5,360#	7,030#
114"	1,170#	1,960#	2,660#	3,610#	4,200#	4,850#	6,360#
120"	1,060#	1,720#	2,420#	3,280#	3,810#	4,400#	5,780#
126"	970#	1,570#	2,210#	3,000#	3,480#	4,020#	5,280#
132"	890#	1,440#	2,030#	2,750#	3,200#	3,690#	4,840#
138"	820#	1,330#	1,870#	2,540#	2,940#	3,400#	4,460#
144"	760#	1,240#	1,730#	2,340#	2,720#	3,140#	4,120#

Beam Series:	SBTCG500*	SBTCP550	SBTCG550*	SBTCP600	SBTCG600	SBTCB600	SBTCW600
Beam Height:	5.00"	5.50"	5.50"	6.00"	6.00"	6.00"	6.00"
Beam Length	Capacity	Capacity	Capacity	Capacity	Capacity	Capacity	Capacity
48"	15,000#	15,000#	15,000#	15,000#	15,000#	15,000#	15,000#
54"	15,000#	15,000#	15,000#	15,000#	15,000#	15,000#	15,000#
60"	15,000#	14,260#	15,000#	15,000#	15,000#	15,000#	15,000#
66"	13,830#	13,050#	15,000#	14,860#	15,000#	15,000#	15,000#
72"	12,750#	12,040#	14,890#	13,710#	15,000#	15,000#	15,000#
78"	11,820#	11,180#	13,820#	12,720#	15,000#	15,000#	15,000#
84"	11,030#	10,440#	12,900#	11,880#	14,710#	15,000#	15,000#
90"	10,350#	9,810#	12,100#	11,150#	13,810#	15,000#	15,000#
92"	10,153#	9,623#	11,867#	10,937#	13,540#	15,000#	15,000#
96"	9,760#	9,250#	11,400#	10,510#	13,000#	15,000#	15,000#
102"	9,230#	8,760#	10,790#	9,940#	12,290#	14,480#	15,000#
108"	8,430#	8,320#	10,240#	9,430#	11,660#	13,730#	15,000#
114"	7,610#	7,930#	9,740#	8,990#	11,090#	13,070#	14,780#
120"	6,910#	7,370#	8,840#	8,590#	10,580#	12,450#	13,970#
126"	6,300#	6,740#	8,060#	8,210#	9,930#	11,440#	12,710#
132"	5,780#	6,170#	7,390#	7,560#	9,090#	10,470#	11,630#
138"	5,320#	5,690#	6,810#	6,960#	8,360#	9,620#	10,690#
144"	4,910#	5,260#	6,290#	6,430#	7,710#	8,870#	9,860#

*NOTE: The next higher profile in a "P" series beam (SBTCPxxx) may be a better value!

IMPORTANT NOTES AND CAUTIONS REGARDING THESE CAPACITIES!

EXAMPLE: SBTCG500096 is a step beam with a bolted connector for tubular rack, 5.0" high x 96" long, capacity 9,760#/pair.

Capacities in pounds per pair, over top (not step) of beams, *uniformly distributed*; **concentrated, seismic, and impact loads reduce capacity**

These capacities based upon the lesser of the strength in bending or L/180 criteria. Safety factor=1.67:1.

When beam length allows only one load wide per level, decrease above capacities by 20% for impact loading.

These *component* capacities are based upon RMI 1997 design specifications. *System* compliance with RMI 1997 requires you to provide *complete* details of the configuration of the system (beam levels, load per level, beam spacings, upright frame height and types, etc).

Beams greater than 108" in length MUST have (1) beam tie per pair to achieve these capacities.

Applications with loads of greater than 7,500# per level should not use "P gauge" upright frames (BTFAP, BTFBP, BTFCP).

Above capacities are for non-seismic interior selective applications; contact factory for seismic capacities or other non-standard applications.

Based upon a MINIMUM steel yield of 60,000 p.s.i.

Other beams available (other gauges, profiles, yields) in large quantities; call factory for details.

NOTE: On SK2500 rack, step beams are bolted above the beam. Make sure to order uprights minimally 2" higher than the top beam level!

SK2500 Step Beam Details- NEW as of 6/2004

2.5" Step Beam

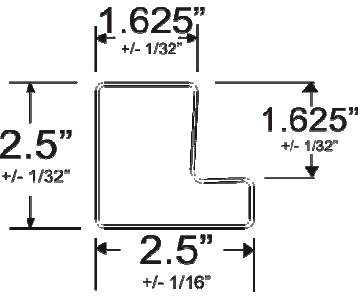

3" to 4.5" step beams

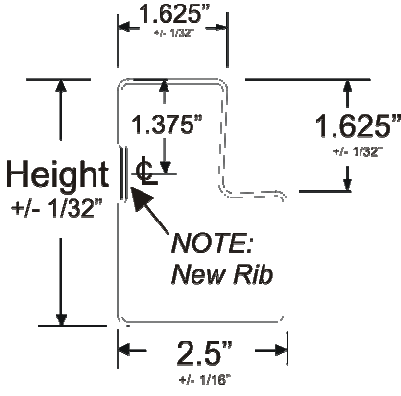

5"-6" step beams

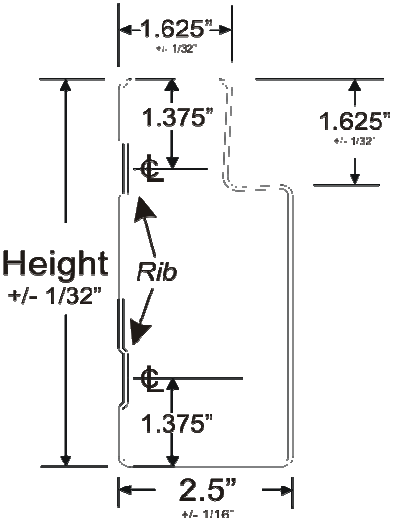

Rib detail

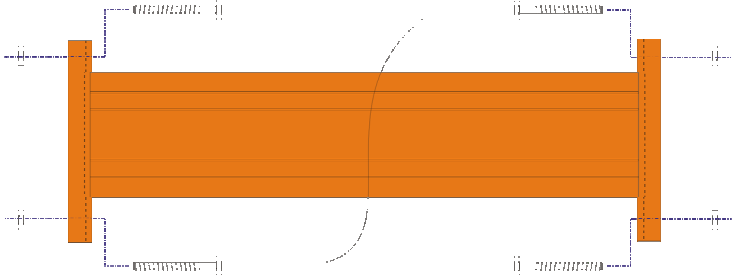
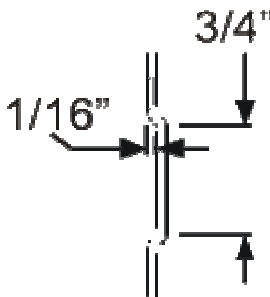

NOTE: On SK2500 rack, the step beam connection is bolted above the beam.
Make sure to order uprights minimally 2" higher than the top beam level!