

Cantilever Rack User's Manual

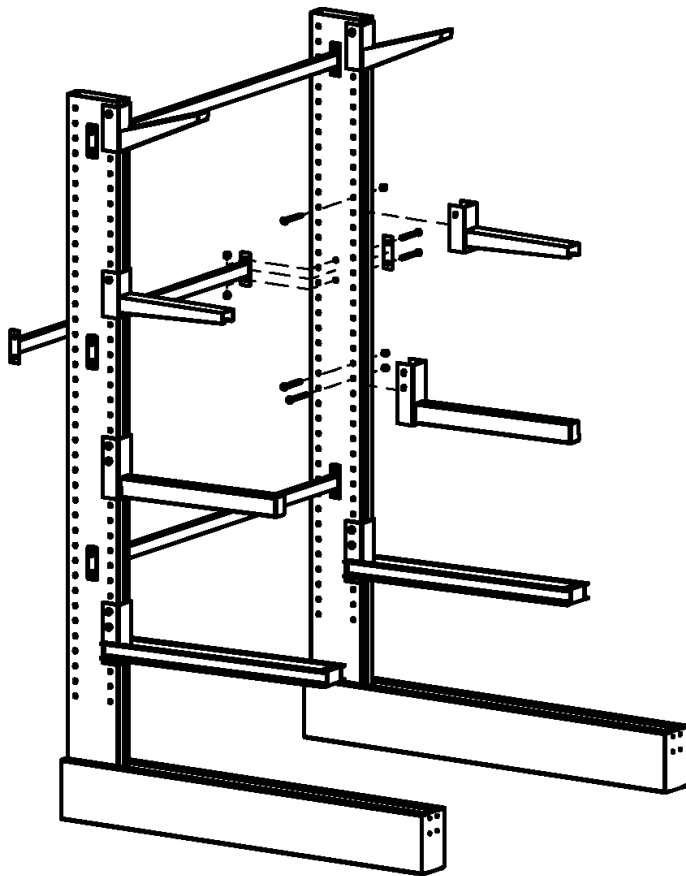
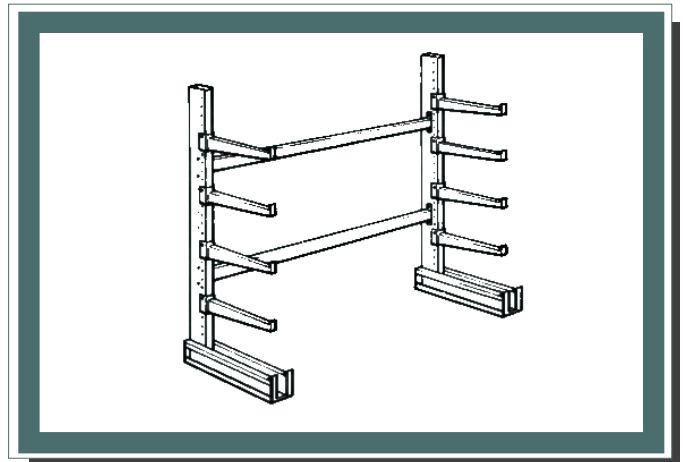

This manual contains:

- 1) Assembly and installation information
- 2) Maintenance information

Correct assembly, installation, use, and maintenance are critical to the safe operation of your cantilever rack system.

ALL PERSONNEL WHO COME IN CONTACT WITH THE CANTILEVER RACK SHOULD READ THIS MANUAL CAREFULLY!

Operators of industrial lift trucks must be trained and certified per OSHA regulation 29 CFR 1910.178.

Keep this manual in a convenient location, for future reference, retraining, and orientation of new users of the product.

Guide to symbols in this manual:



figure 1

DANGER is indicated by a red exclamation point within a red triangle, as shown in figure 1. These symbols denote situations which could cause damage, injury, or death.



figure 2

CAUTION is indicated by a yellow exclamation point within a yellow triangle, as shown in figure 2. These symbols indicate situations which require an extra measure of your attention.



STEEL KING®

Steel King Industries, Inc.
2700 Chamber St
Stevens Point, WI 54481

(800) 826-0203

info@steelking.com

www.steelking.com

Thank you for your purchase of a Steel King cantilever rack system.



Read these instructions before assembling or using your cantilever rack system. To obtain the maximum benefit from any cantilever rack system, and for the safety of those around the rack, the rack must be properly assembled and maintained. The information in this booklet will assist you in fulfilling your responsibility to provide a safe, properly maintained cantilever rack assembly.

Assembly Information



Cantilever racks should be assembled only by trained personnel, experienced with proper cantilever rack assembly procedures.



Improper cantilever rack assembly can not only cause poor performance of your system, but can also pose a safety hazard in your facility.

If you are unfamiliar with cantilever rack assembly, you should contact Steel King or your Steel King Distributor for professional rack assembly services. Steel King cannot provide guarantee or warranty coverage for any system assembled by anyone other than a Steel King approved Installation Contractor.

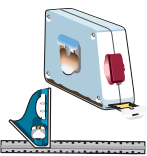

It is very important that the cantilever rack structure be installed in a plumb, level, and square condition.

Since few floors are perfectly flat, shimming of the cantilever racks is frequently required. A four foot long carpenter's level is a good choice for checking level and plumb conditions on cantilever racks of average proportions. A vertical tolerance of 1/8" in 4 feet (or other as specified on Steel King installation drawings) is generally acceptable.



The cantilever rack structure should be assembled and used only as shown on Steel King's assembly drawings.



Changing the configuration (such as adjusting arm levels) can adversely affect the load carrying capacity and reduce the structural integrity of the cantilever rack system. Before adjusting the rack configuration, contact Steel King or your Steel King Distributor, to verify the safety and structural adequacy of the new configuration.



"Nut and Bolt" connections are to be tightened to a snug and secure condition.

For typical Grade 5 hardware, torque to:
 60 foot-pounds for 1/2" diameter hardware
 120 foot-pounds for 5/8" diameter hardware
 200 foot-pounds for 3/4" diameter hardware

Tightening to the point of crushing tubular components is to be avoided.

All hardware needs to be in place and properly tightened before the cantilever rack system is to be used.



Every cantilever column/base must be anchored to an adequate concrete floor.



- For **Light-duty Cantilever Rack**, the normal anchor connection is (2) 1/2" diameter x 3-3/4" anchors for single-sided applications; and (3) 1/2" diameter x 3-3/4" anchors for double-sided applications.
- For **Standard-duty Cantilever Rack**, the normal anchor connection is (2) 5/8" diameter x 4-3/4" anchors for single-sided applications; and (3) 5/8" diameter x 4-3/4" anchors for double-sided applications.
- For **I-Beam Cantilever Rack**, the normal anchor connection is (3) 3/4" diameter x 5-3/4" anchors for single-sided applications; and (5) 3/4" diameter x 5-3/4" anchors for double-sided applications.

Anchor bolts are not included with Steel King cantilever rack systems unless specifically detailed on the Bill of Materials.



Since anchor bolts vary in strength, if you are purchasing your own anchor bolts, contact Steel King or your Steel King Distributor for minimum anchor specifications for your installation.



Since concrete floors vary greatly in design and load carrying capacity, Steel King cannot guarantee that a particular concrete slab is adequate to support a particular cantilever rack installation. The characteristics of the slab should be obtained from the building architect before the cantilever racks are specified, so that the cantilever rack supplier can design the rack to suit the slab.



Do not install cantilever racks outdoors, unless specifically designed by Steel King for this purpose. Outdoor usage requires consideration of wind loads, snow loads, etc., which are not normally considered in cantilever rack design.

Assembly Information (continued)

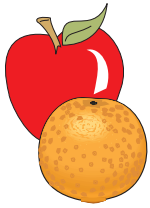

Be cautious when intermingling new and existing parts. Even components produced by the same manufacturer can vary in design. Many manufacturers offer a variety of basic designs, and designs are often altered slightly over the years to improve performance. These differences can adversely affect the overall performance and safety of a cantilever rack structure.

Many cantilever rack systems have such similar designs that a rack system can be assembled using parts from more than one manufacturer. However, since Steel King has no control over the quality of components designed and manufactured by other firms, any and all warranties and guarantees are made void if non-Steel King parts are used in conjunction with Steel King parts.



Installation of "capacity plates" is strongly recommended. These plates should identify the characteristics for which the cantilever rack was designed, such as load size, load weight, and rack configuration. These plates are very useful for communicating safe loading information to both present and future users. Several signs should be prominently located for easy visibility, and be permanently affixed to the rack structure. Appropriate signs can be obtained locally, through industrial mail order catalogs, or from Steel King or your Steel King Distributor.



Never climb on cantilever racks, during or after assembly. Cantilever racks are not designed to be stepped on or climbed on. A slip or fall may result in serious injury.



It is your responsibility to communicate this important warning to all who come into the proximity of your cantilever rack. This communication can include training and appropriate signage. If your cantilever rack is used in a retail environment, prominently placed, high visibility warning signs are especially helpful in preventing this misuse of a cantilever rack structure.

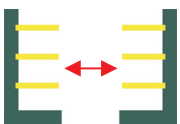

Allow adequate aisle spacing. Aisles which are too narrow for the handling equipment, or are reduced in size by obstructions increases the danger of collisions between the lifting equipment and the rack structure, and may cause a danger to pedestrian traffic.



Maintain adequate clearances around loads. These include those dictated by local fire codes (such as between the uppermost load and the roof structure). Also between loads and vertical members. Clearances which are too tight could increase fire risk, will decrease handling speed, and increase the likelihood of damage to rack components and/or loads.



Install good lighting in every rack aisle. Good lighting improves handling efficiency, prevents accidents, and reduces accidental damage to the rack structure.



Do not cut, weld, or in any other way modify any component of your Steel King cantilever rack. Such modifications may decrease the load carrying capability of the component, and the weakened component can jeopardize the integrity of the entire rack structure. Any modification of any component, except as performed or authorized in writing by Steel King Industries, Inc. engineering personnel, will make null and void any warranties and guarantees.



Operational & Maintenance Information



Perform regularly scheduled inspections (at least annually) and maintenance of the rack system.

Check for:

- All hardware (including anchors) properly tightened
- All cantilever racks plumb, level, and square
- No dents, kinks, or otherwise damaged components
- Load sizes and weights match original specifications



Replace damaged or missing components immediately! Unload damaged cantilever racks immediately, and contact Steel King or your Steel King Distributor for replacement parts (damage reduces capacity, creating the potential for collapse and injury).

Check finish, touch up chips or scratches, to prevent corrosion.

Operational & Maintenance Information Continued



Train the operators, and maintain the equipment they use in conjunction with the cantilever racks.

Minimizing actual contact between the cantilever racks and the handling equipment is the most important factor affecting rack longevity. Educate cantilever rack users to avoid "impact loading" (dropping loads onto the cantilever arms), how to position loads for even distribution of load weight, report any cantilever rack damage, etc.



Do not overload any cantilever rack component, bay, or system. Your cantilever rack is designed to support a specific load weight, in a specific configuration. Should your load weights or sizes change, contact Steel King Industries before using the rack to store the new loads. Using your rack in any manner other than originally configured could lead to rack collapse and injury.



Fig. A Total Load 1000 lbs.



Fig. B Total Load 1000 lbs.

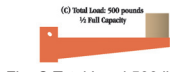

Fig. C Total Load 500 lbs.

Required arm capacity equals "load weight" divided by "number of arms supporting load per level" Cantilever arm capacity is based on uniformly distributed loads as show in figures A & B. Loading patterns shown in figure C reduces arm capacity by 50%.

Required upright capacity is based on "number of arms per side of upright" multiplied by "load per arm."



Determining the number and spacing of cantilever support arms is critical to determining correct capacity.

Use enough arms under a load to prevent deflection of the load. Deflection causes undesirable side pressure on the arms.

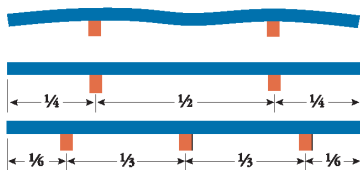

If no load deflection is present using (2) arms to support load, the arm capacity required is 1/2 the load weight.

If deflection occurs with (2) arms, try (3) arms. If this system works, the arm capacity required is 1/3 of the load weight. Continue to add arms as necessary until deflection is eliminated.



Loads are not to be placed on the ends of arms and then pushed back into place. The back of the load should be over the back of the arm and then lowered into place. Loads are to be flush with the back of the arm and are not to overhang the front of the arm, unless specifically designed to do so by Steel King.

In addition, loads shall not be placed on arms and side shifted left or right.



Be certain that fork truck is equipped to protect operator from accidental crushing against cantilever rack, loads, and other objects. If operators would be exposed to such dangers, contact the manufacturer and/or reseller of the fork lift equipment, and demand that protective devices (such as a protective rear post on stand up type trucks) be immediately installed on the equipment to protect the operator.

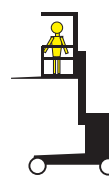

Be certain that fork truck is equipped to protect operator from accidental falls. Platforms upon which operators stand must be of a type that is approved by the lift equipment manufacturer and OSHA. Operators should be restrained or otherwise protected from falling off of the equipment. If operators would be exposed to such dangers, contact the manufacturer and/or reseller of the lift equipment, and demand that protective devices be immediately installed on the equipment.



Establish good housekeeping practices. Keep aisles clear of litter or obstructions, do not use aisles for floor stacking materials. Keep aisle surfaces clean and free of ice and condensation, so handling equipment travel is not affected.

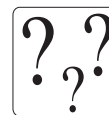

Do you have any questions about your Steel King cantilever rack, it's assembly, operation, or maintenance? We would be pleased to assist you. Contact Steel King or your Steel King Distributor with any questions.

Steel King Industries, Inc.
2700 Chamber Street
Stevens Point, WI 54481

phone (800) 826-0203
fax (715) 341-8792
info@steelking.com
www.steelking.com

Form CRUM0409 copyright 2009 Steel King Industries, Inc.